

Over Armour Offroad

2515 Bypass Rd Flemingsburg, KY 41041

606-845-7439

Instructions for Installation and Care of Can-Am Commander Full Cab Enclosure w/Polycarbonate CA-COMMANDER-FC04

CAUTION: Do not smoke inside the cab or expose the enclosure to direct flames. Product is FLAMMABLE.

Be sure to read these instructions thoroughly before opening and installing the enclosure. The installation is best done when ambient temperature is 70°F or warmer. If installed in cold weather, warming the adhesive Velcro strips before installation is recommended.

1. Carefully open the carton and remove the rolled-up Cab Enclosure on a large flat surface that is clean and free of dirt or other material that may soil or scratch the windows of the Cab.
2. This cab enclosure is made up of 5 different panels that all come together to fully enclose the vehicle. You may put on different pieces or leave other pieces off to create the enclosure that best meets your needs.
3. Check over the parts included in the carton with the parts list shown below:

The following list is split up in different parts, you may not need all the parts listed to install the enclosure depending upon which parts you do or don't install.

Doors:

Velcro Hook strips-----4 each-----12” long
“ “-----2 each-----6” long
“ “-----2 each-----8” long
“ “-----16 each-----3” long

Snap studs-----14 each (2 extra)

Door Panels-----2 each

Rear Window:

Velcro Hook strips-----4 each-----3” long

Rear Window Panel-----1 each

Top:

Velcro Hook strips: -----4 each-----6” long

Double-Sided Velcro w/ 30” Straps Attached ----- 4 each

30” Straps with grommets ----- 2 each

Top Panel ----- 1 each

4. For these instructions we will be installing the entire enclosure. This will cover every piece so if you should want to install just parts of the enclosure these instructions should be sufficient.
5. The order of installation will be as follows:

- a. Rear Window
- b. Side Doors
- c. Aero-Vent Polycarbonate Windshield
- d. Top Panel

6. Rear Window Panel

- a. Before installing the Rear Window Panel, you will need to remove the seats and set them aside.
- b. Begin installation by hanging the rear window from the top by using the 6" adhesive Velcro strips as shown in the photos below:

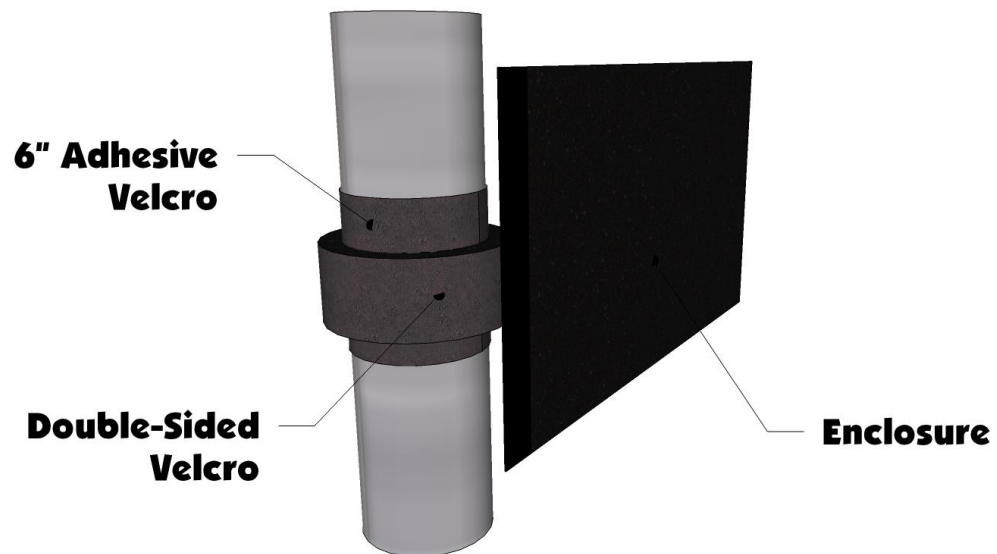
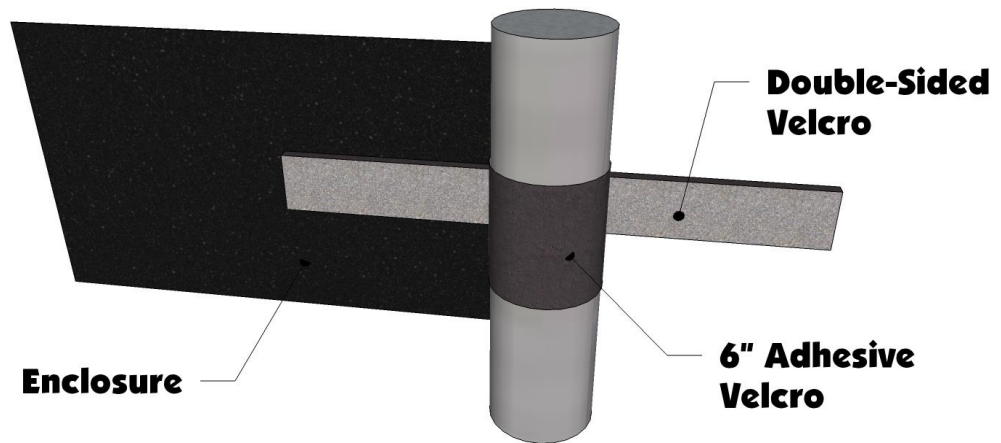

- c. Make sure that the Rear Window is centered correctly and then move to the bottom of the panel and take the straps down and around the side bars and then up and through the ladder lack. Do NOT pull them too tight because when the seats are replaced they will be pushing on the rear window. See Photo Below:



- d. For now, leave the sides of the Rear Window unfastened. We will get to that after the Doors are installed. If you are not planning to install the doors at this point you can go ahead and attach the sides like you did the previous points along the top of the Rear Window.

7. Door Panels

- a. Begin installation of the Door Panels by hanging them from the Double-Sided Strips along the top of the doors. Hold the door up and mark where each strip is and wrap a 6" adhesive strip around the roll cage. Now hang the door up and it will be in place to install the rest of the Velcro for the door. See Photo Below:

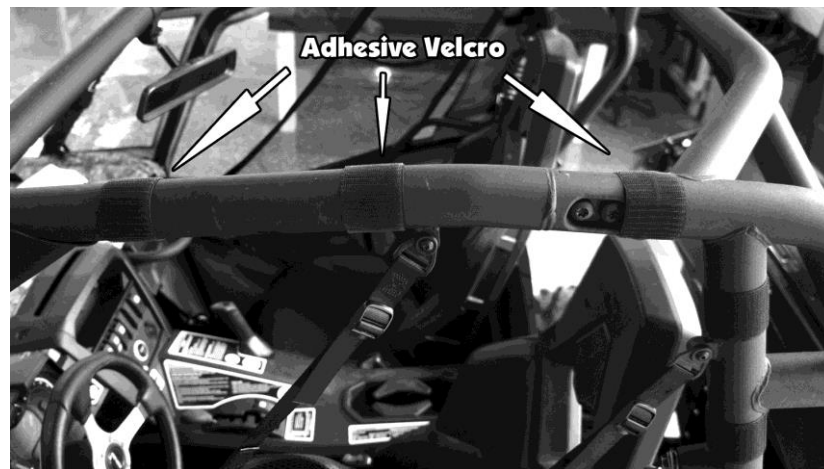

- b. Now move around the door and attach the remaining Velcro strips in the same manner.
- c. You will notice that the top four straps along the rear of the door also have a ladder lock buckle attached to it. These buckles are for the straps sewn to the sides of the rear window and we will get to that soon.
- d. Next work your way around the bottom of the door panel and install a snap stud for every snap on the Door Panel. **TIP: You may find it easier to snap the screw stud into the socket on the door first and then pull the Door Panel to the position it should be in and push the screw into the plastic to mark its position. Then remove the screw stud from the socket and drive it into the plastic.** See Photos Below:

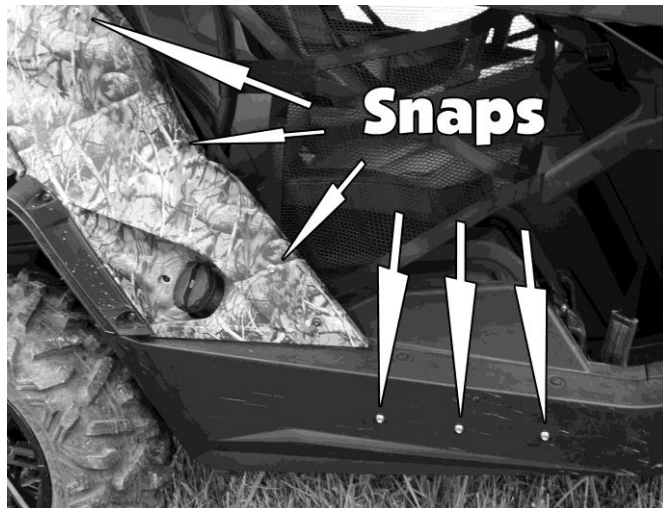

- e. Save the two snaps on the front lower portion of the door until last. These will go into the plastic down around your feet and should be facing towards the rear of the vehicle. See Photo Below:

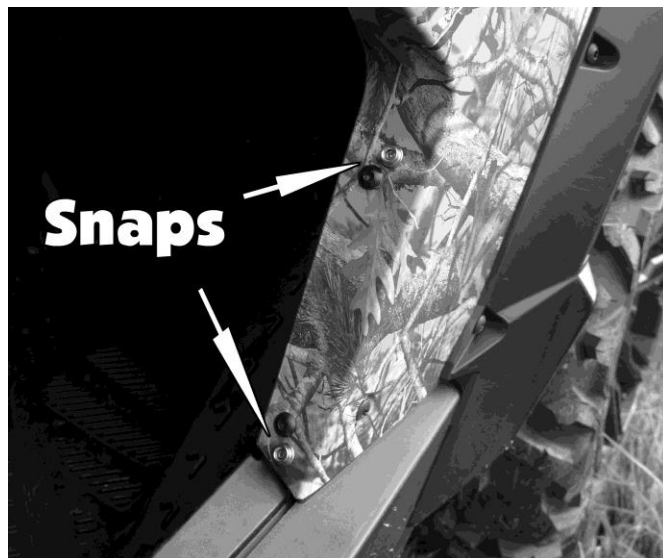

- f. Lastly on the door you will take the strap that is sewn to the center webbing strip towards the front of the door and run it through the safety net buckle and back to the ladder lock buckle. You may need to adjust the length so that it is not hard to buckle the webbing when entering the vehicle. See Photo Below:



- g. Now you can go back to the sides of the Rear Window Panel and run the straps on the Rear Window through the ladder lock buckles on the Door Panels. You will not need the double-sided Velcro strips sewn to the Rear Window and should tuck them away down between the two pieces. These Velcro strips are for when you want to install the Rear Window Panel without doors.

8. Aero-Vent Polycarbonate Windshield

Install as shown in the directions included with the windshield.

9. Top Panel

- a. First take the two straps with grommets in the end and bolt them to the Polycarbonate windshield through the hole in the bottom corners. The bolt should be installed from the inside out with a washer then strap, another washer and a locknut. Tighten all the way down and then loosen the locknut $\frac{1}{2}$ a turn to free the strap to allow it to swing around to any position.
- b. Now place the top over the entire vehicle, the front of the top is identified by the sides not being as steeply curved, and begin lacing the front straps through the ladder lock buckles sewn to the front corners of the top.
- c. Now take two of the straps that are sewn to the double-sided Velcro and wrap them around the rear bar of the roll cage halfway between the bottom and the first bend up the bar. The strap should be on the outside of the bars.
- d. Now run those straps up and through the ladder lock buckles sewn to the rear of the top.

- e. You now need to tighten and loosen the strap of the top so that it is centered correctly and should cover the holes across the top of the windshield.
- f. If you were installing the Top by itself, you would use the two remaining straps with double-sided Velcro to attach the front. You may need to cut the straps once fitted, do not cut off too much as you have nothing to hold on to and pull it tight the next time you go to install it. It is recommended to leave about 6-8" hanging from the buckles.
- g. Now install the top brace of the windshield as shown in the windshield instructions.

Cleaning and Storage Recommendations:

1. Before removing the Over Armour Offroad Cab for storage, make sure it is very clean in order to prevent scratching of the window panels. Clean with a soft rag or sponge using a mild liquid detergent soap and warm water solution. Never rub the windows with a dry cloth or rag! Let the Cab dry thoroughly before attempting to roll for storage.
2. It is important that the Cab be rolled up for storage rather than folding. Folding will cause damage to the windows!!! Carefully roll up the Cab similar to the way it was when it was packed at the factory. On a large, clean and flat surface, fold the doors over the rear panel first, then, interleave the top and windshield on top of the doors. Begin rolling the Cab into a roll approximately 8 inches in diameter. Put the rolled Cab back into the carton for storage at a normal room temperature. It is best not to expose the Cab to either extreme hot or cold temperatures when storing.
3. A special cleaner conditioner is available from Over Armour Offroad that will greatly increase the service life of the Cab Enclosure. In addition, if additional hook and loop sets are needed, they can also be ordered.

Return Policy

Over Armour Offroad

2515 Bypass Rd, Flemingsburg, KY 41041
Phone: 606-845-7439

If for any reason you choose to return this product it must be returned within **30 days from date item is received**. You **MUST** package the product exactly as it was **originally packaged from the factory to get a full refund for the product!**

The vinyl windows should never be folded when packaging in the box or for storage purposes. Lay all the windows on top of each other with the canvas folded in between and the paper (if available) on both sides of the windows.

All returned products will be inspected upon arrival at the production facility and must be in unused, factory new condition to receive refund - a 20% restocking fee will apply.

If ordered from Over Armour Offroad please call at 606-845-7439 to gain a return authorization number, use our preferred shipping carrier (UPS) to return the item (unless the item is defective, you are responsible for paying the shipping to return the item.) **Any returns submitted to Over Armour Offroad without a return authorization number will be charged a 20% restocking fee.** If ordered from one of Over Armour Offroads many distributors', you must first call them and see what their return policy is. Once your item reaches our production facility, our customer satisfaction team will inspect your item to ensure unused, factory new condition. **NOTE: All windshields must be returned with the original protective film intact and not removed. Do NOT REMOVE if you have any intentions of returning the item. Refund/ replacement of a windshield will only be processed on items with original protective film or if the windshield is defective.**

Items must be properly packaged in the original shipping carton to protect them during transit and ensure your returned item arrives back factory fresh, and in new resalable condition (**any returned items that have been used, altered or damaged in any way will not be subject for a refund.**) All contents including instruction manuals, accessories, hardware, Velcro, etc. must be included in your return shipment. Only items in OEM factory new condition will be approved. Once returned items are received, credit will be issued to the original credit card/ payment method used for the purchase. Outbound shipping and return shipping cost will not be refunded. Please allow 4 to 6 weeks for your refund to be processed.

Warranty

Over Armour Offroad

2515 Bypass Rd, Flemingsburg, KY 41041
Phone: 606-845-7439

To The Owner of this Product:

Thank you for purchasing one of Over Armour Offroad Cab Enclosures &/or Windshields! Below are the terms under which your product is covered under our manufacturer's warranty.

30 Day Warranty which includes and is not limited to replacing the enclosure and/or windshield due to defect of the product. Please refer to the return policy in this case for more information.

1 Year Warranty includes any defect in material or workmanship within this time frame we will gladly correct the problem or replace the enclosure &/or windshield. Upon submitting for the correction or replacement we will need to receive pictures of the defect in material or workmanship along with the receipt from the date of purchase.

Thank you,

Darren Royse
Owner/Operator

www.overarmouroffroad.com